

EJOT® Frame anchor Type RA-P

Technical Product Information (TPI) - Nr. 31/I./GB/05.2009

The EJOT® Frame anchor Type RA-P, specially made for a standard RAL- quality assembly for plastic windows in brick work and concrete. It is usable for a direct attachment in old and new buildings without any dowel.



The frame anchor specially made for a standard RAL quality assembly, for plastic windows in brick work and concrete

Technical Data

Thread geometry	special thread with cutting notches and reduced tip
Thread diameter	7,5 mm
Head	broad seated head
Head diameter	11 mm
Drive	TORX® T30
Surface	zinc-plated, blue passivated
Layer thickness	min. 8 µm
Length	see next page

with tough
TORX® T30 drive

Special Properties

- The EJOT® Frame anchor Type RA-P transfers safely all kind of accruing charges especially mechanical loads vertically to the window front (e.g. wind load). The broad seated head enables a bump free load distribution on the plastic frame. There is no radial force applied into the subsurface.
- There is a solid corrosion resistance because of the high quality 8µm zinc coating.
- Concerning the TORX® T30 drive, it is safely possible to transfer a higher installation torque in hard building materials, like concrete or sand-lime brick. All in all there is a high durability of screwdriver bits.
- The special thread geometry with cutting notches and reduced tip scales down the installation torque. This fact grants a perfect workability even under hard working conditions and high assembly performances.

Processing and Installation

EJOT recommends to follow the instructions of the RAL- quality association "Installation Guidelines", for a safe and systematic installation. Also follow the technical specifications of the window producer.

Installation

- Pre drill the frame with a diameter of 6,2 mm. Distance and disposal according to RAL "Installation Guidelines" is minimal 700 mm in plastic window frames. Distance to inner corners should be 100 – 150 mm.
- Adjust the frame in the bay and wedge it with some plastic or wood cotters according to RAL quality "Installation Guidelines"
- Drill with a 6mm ø drill bit, through the pre drilled frame holes, into the brick work or the concrete. The minimum drill-hole-depth is screw in depth + 10 mm. **In vertical coring brick and other vacant chamber material don't use the hammer drill for pre drilling! It is not necessary to pre drill in cellular concrete!**
- Fasten the EJOT® Frame anchor Type RA-P with a cordless screwdriver or similar. Do not tighten the anchor too fast to avoid tension in the frame.
- Install the EJOT® Cover caps RA-P in the right colour.
- **Minimal screw-in depth:**
Concrete (C25/30): 30 mm
Sand-lime brick, solid brick: 40 mm
Cellular concrete (PPW4), vertical coring brick: 60 mm
- For not named or unknown material please contact the **EJOT® Application Engineering IFF!**

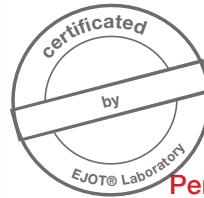
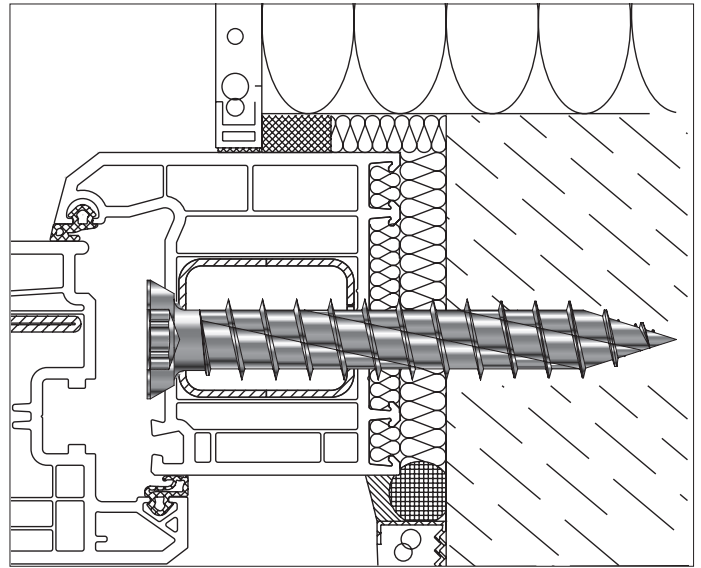

Performance Data / Certificates

Performance data / certificates can be provided on request.



Our Recommendation

Clients who bought the EJOT® Frame anchor Type RA-P also ordered:

Drill hole diameter in mm	Length in mm	Packing unit (pieces)	Order description
Zinc-plated, blue passivated			
7.5	40	1.200	310 40 60 1
7.5	50	1.200	310 50 60 1
7.5	60	1.200	310 60 60 1
7.5	70	1.200	310 70 60 1
7.5	80	1.200	310 80 60 1
7.5	90	600	310 90 60 1
7.5	100	600	311 00 60 1
7.5	120	600	311 20 60 1
7.5	135	400	311 35 60 1
7.5	150	400	311 50 60 1
7.5	180	400	311 80 60 1
7.5	210	400	312 10 60 1

Product description	Colour	RAL	Packing unit (pieces)	Order description
EJOT® Cover caps	grey	7036	500	000 19 60 0
	clay brown	8003	500	000 80 60 0
	brown	8011	500	000 12 60 0
	creme	9001	500	000 28 60 0
	white	9010	500	000 11 60 0
	black	9011	500	000 13 60 0

	Drill hole diameter in mm	Length in mm	Packing unit (pieces)	Order description
EJOT® Window sill screw	4.2	20	500	900 23 30 0
EJOT® Window carrier strap TG1		TG1	10	000 60 08 6
EJOT® Window carrier strap screw	5.5	22.5	500	840 62 60 1
EJOT® Hammer drill SDS plus	6.0	150/210	10	000 70 00 1
EJOT® Hammer drill SDS plus	6.0	200/260	10	000 70 00 2
EJOT® Bit TORX T25		70	10	190 000 800 22

Good to Know – Some Useful Tricks

The function of frame anchors in window fastening is to transfer the charges vertical to the window front, so primary the wind charges. With the EJOT Frame anchor you can also do other fastenings, quick and easily.

TPI Nr. 31/I./GB/05.2009:

This technical information is based on the state of the art and our own experiences.

In respect of the multiplicity of the sub surfaces and special object conditions every client has to assume full responsibility to use our products at own risk and choose the compatible product for his application. In case of issuance of a revised technical information data sheet, this document will automatically expire.